

Harbour Patrol Launches “Marine 117 & 119” for HKSAR Marine Department

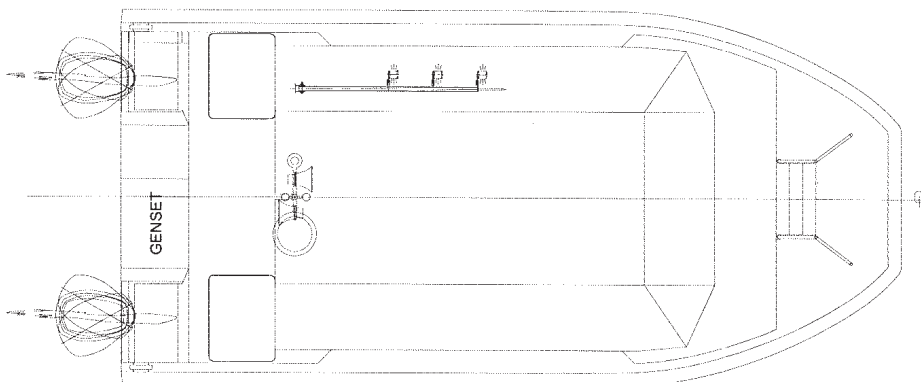

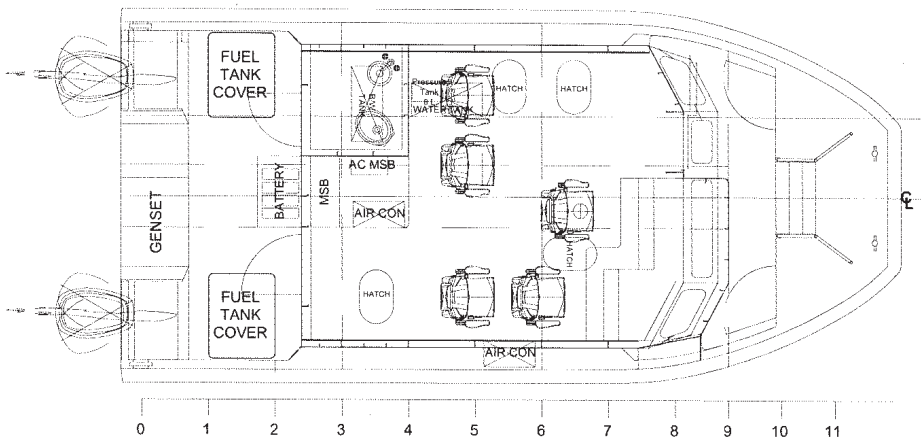
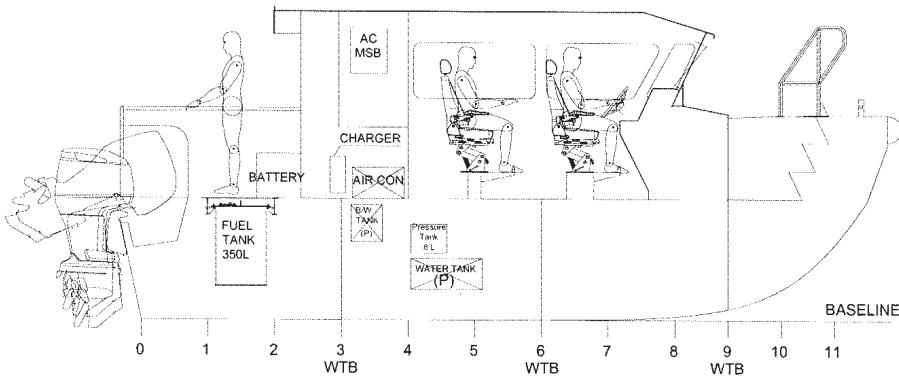
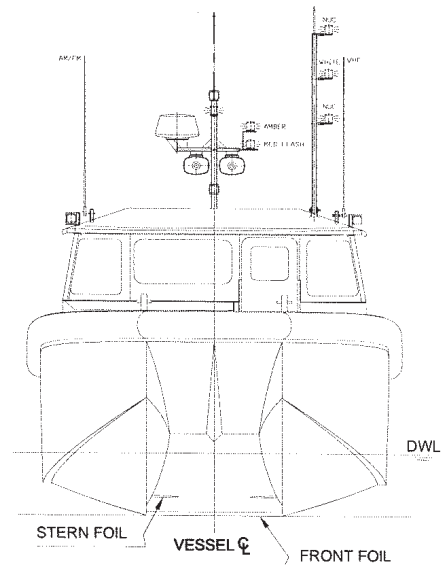
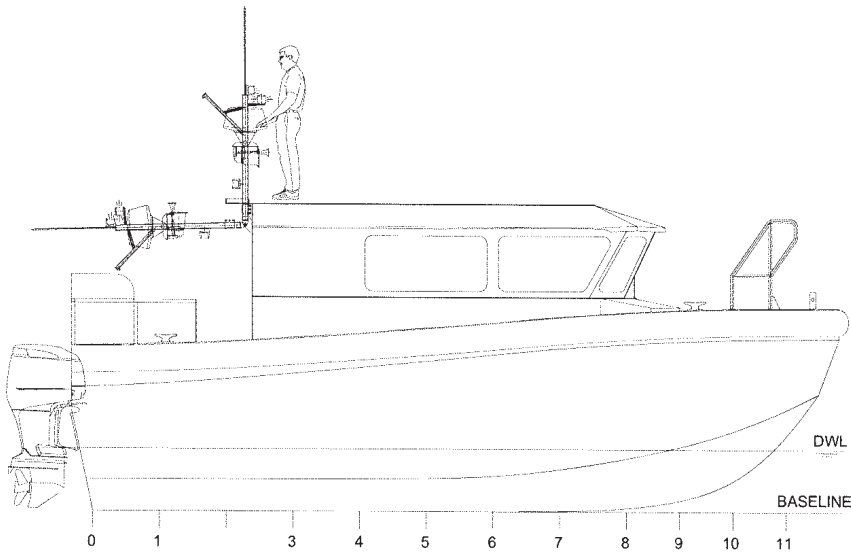

**AS FITTED**  
20-01-2015

Note : Indicate position of fresh water tank and Black water tank inside Port side and air condition inside Starboard side of hull

**VESSEL PARTICULARS**

LOA	10.21m
LWL	7.8m
MAX BEAM	4.195m
MOULDED BEAM	3.9m
MAX DRAFT	0.7m
MAX AIR DRAFT	2.75m
MAX SPEED	35 knots
ENGINES	2 x 250 HP OUTBOARDS
CREW	2
PASSENGERS	3
FUEL CAPACITY	2 x 350 Litres

**HAWC**  
HONG KONG ASSOCIATED WATER CRAFT

HAWC



**WANG TAK ENGINEERING & SHIPBUILDING CO., LTD.**  
宏德機器鐵工廠有限公司

File.	Y14001&2	AL CATAMARAN SPEEDBOATS	Scale	1:20@AO
Design.	HAWC/WTES	FOR MD HP -MARINE 117 & 119	Rev	AF
Drawn.	YC CHAN	<b>General Arrangement</b>		
Checked.	YC CHAN			
Approved.	F.SZETO			
Date.	20-01-2015	Dwg no.	Y14001-G-01	1